

A7 Pro Flying Probe Test System

For Rigid and Flexible Boards



- ▲ 8 Test Heads
- ▲ 20 % higher mechanical speed than A7
- ▲ Light weight Carbon Z-Axis
- ▲ 4 High Resolution Color Cameras
- ▲ Fast 300 mA Kelvin Testing

A7 Pro Technical Specifications

Flying Probe Test System

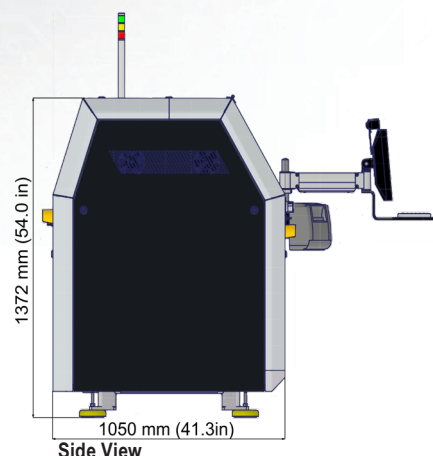
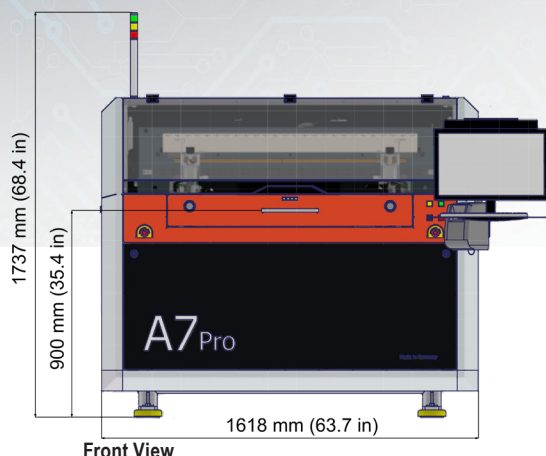

Mechanics

Basic unit with 8 probes (4 top, 4 bottom)
 Universal shuttle system with clamp and stretch mode for testing flexible and rigid boards. Pneumatic clamping function controlled by foot switch.

Max. board size (X x Y)	640 mm x 610 mm / 25.2" x 24.0"
Min. board size (X x Y)	10 mm x 10 mm / 0.4" x 0.4"
Test area (X x Y)	610 mm x 510 mm / 24.0" x 20.0"
Board thickness	up to 10 mm / 0.4"

Smallest pad	35 μ m / 1.4 mil* (special setup)
Smallest pitch	100 μ m / 4.0 mil
Resolution measurement system	$\pm 0.1 \mu$ m / ± 0.004 mil
Repeatable accuracy	$\pm 4 \mu$ m / ± 0.16 mil

Soft touch probes or	5 g to 10 g
*Micro needle probes	0.3 g to 2.5 g

Electronics

Continuity test	1 Ω to 10 k Ω
Isolation test	up to 25 M Ω (FM) up to 100 G Ω (ohmic) MicroShort Detection [®]
Test voltage	100 mV to 1000 V

Camera System

4 color cameras for fast optical scanning of top and bottom side.
 Resolution 6 μ m/pixel

Options

- 4-wire measurement with max. 300 mA test current

0 Ω to 1 k Ω	$\pm 2 \%$, min $\pm 25 \mu\Omega$
with Kelvin probes	0.3 g to 2.5 g
Smallest pad	80 μ m / 3.2 mil*
Smallest pitch	120 μ m / 4.8 mil*

 * special setup
- Embedded components test

R 0 Ω to 1 M Ω	$\pm 1 \%$, min. $\pm 0.5 \Omega$
1 M Ω to 200 M Ω	$\pm 3 \%$
C 0 F to 100 μ F	$\pm 2 \%$, min. ± 30 fF
L 0 H to 10 mH	$\pm 5 \%$, min. $\pm 0.25 \mu$ H
Diode / Varistor	
U_{EP} , U_{R1} , U_{BR}	0 V to 12.5 V
- LaTest[®] open detection with LaTest[®] probes

High current	1 g to 10 g 1.4 A (1 kHz)
--------------	------------------------------

- Retest of fault files from external grid test systems on inquiry
- Repair software with barcode support

Data input format	IPC-D-356A
Network connection	Ethernet, TCP / IP
Power supply	230 V, 50 Hz (115 V, 60 Hz), 1000 VA
Compressed air	8 bar / 115 psi, filtered
Temperature	18 $^{\circ}$ C to 27 $^{\circ}$ C
Relative humidity	40% to 60%
Machine weight	800 kg

All information subject to change without notice!
 December 2022